

INSTALLATION GUIDE

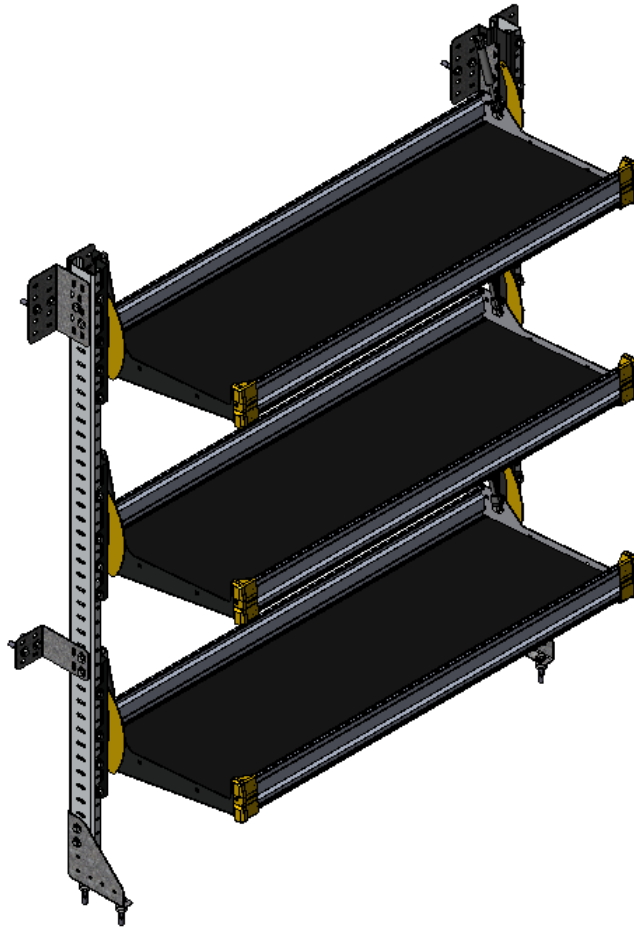

F5-RA48-3 Fold-Away



QUICK START GUIDE

Phase 1 - Assembly

<input type="checkbox"/> 1.1 Setup.....	3 - 5
<input type="checkbox"/> 1.2 Fold-Away Assembly.....	6 - 10

Phase 2 - Installation

<input type="checkbox"/> 2.1 Attach Wall Bracket To The Posts.....	11
<input type="checkbox"/> 2.2 Mark Hole For Plusnut.....	12
<input type="checkbox"/> 2.3 Attach Plusnut.....	13 - 14
<input type="checkbox"/> 2.4 Fold-Away Installation.....	15

REQUIRED ITEMS

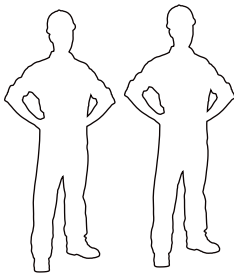

2
PERSONS

- Cordless Impact
- Cordless Drill
- Tape Measure
- Marker
- 1/2" Socket
- 1/2" Drill Bit w/ Drill Collar (Set at 1/2")
- 3/8" Driver Bit
- Knife
- Plusnut Tool / Plusnut Gun (5/16")

PHASE 1 – ASSEMBLY

1.1 SETUP

1.1.1 Unpack components; compare with the bill of materials.

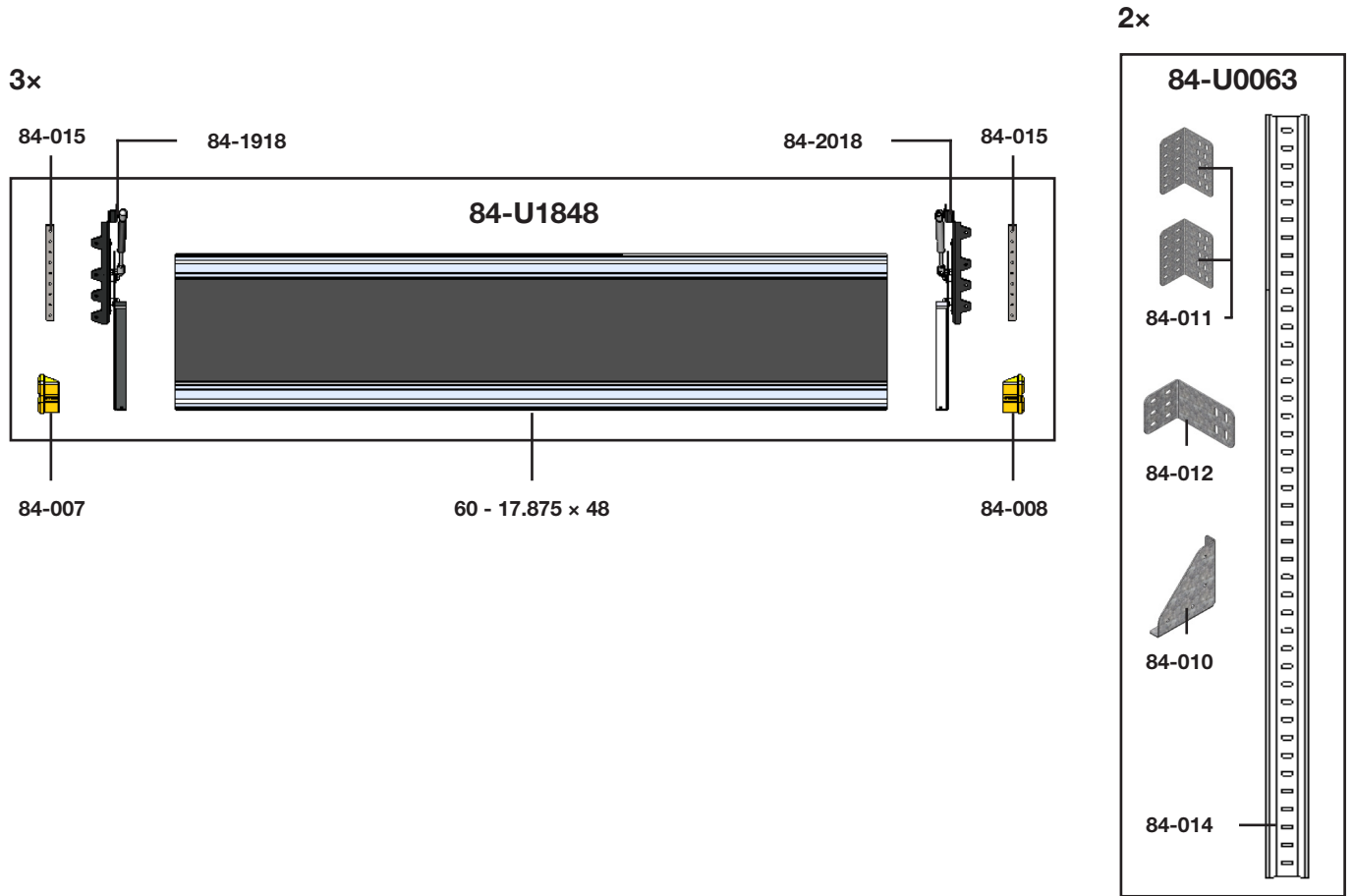

1.1.2 Verify all parts are present.

Item No.	Description	Qty.
84-007	End Cap (Left)	3
84-008	End Cap (Right)	3
84-010	Feet	2
84-011	Top Bracket	4
84-012	Middle Bracket	2
84-014	Post (63")	2
84-015	Threaded Plate	6
84-1918	End Panel (Left)	3
84-2018	End Panel (Right)	3
60-17.875x48	Shelf Tray	3
94-3056	Assembly Fastener Kit	3
96-3038	Install Fastener Kit	3
94-3057	Assembly Fastener Kit	2
96-3039	Install Fastener Kit	2

3x

94-3056



Fastener Assembly

8x



92-102

Screw HWH
#14 x 1"
ZINC

8x



#92-102 Screw #14 x 1"

4x



96-200

Multi-grip alum/steel
3/16" x 1/2"

4x



#96-200 Closed Rivet

3x

96-3038

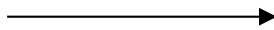

Fastener Assembly

8x



90-204

Hex Bolt
5/16"-18 x 3/4"
GR-5 ZINC

8x



#90-204 Hex Bolt 5/16" x 3/4"

8x



98-116

Flat Washer
5/16"
ZINC



#98-122 Lock Washer

8x



98-122

Lock Washer
5/16"
ZINC



#98-116 Flat Washer

2x

94-3057

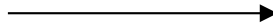

Fastener Assembly

6x



90-204

Hex Bolt
5/16"-18 x 3/4"
GR-5 ZINC

2x



90-224

Hex Bolt
5/16"-18 x 2"
GR-5 ZINC

8x



98-116

Flat Washer
5/16"
ZINC

8x



94-116

Serrated Nut
5/16"-18
ZINC

8x



98-170

Spacer
NYLON

6x



#90-204 Hex Bolt 5/16" x 3/4"



#98-116 Flat Washer



#94-116 Serrated Nut

2x



#90-224 Hex Bolt 5/16" x 2"



#98-116 Flat Washer



#98-170 Spacer



#94-116 Serrated Nut

2x

96-3039

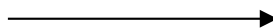

Fastener Assembly

6x



90-212

Hex Bolt
5/16"-18 x 1 - 1/4"
GR-5 ZINC

2x



90-220

Hex Bolt
5/16"-18 x 1 - 3/4"
GR-5 ZINC

8x



98-116

Flat Washer
5/16"
ZINC

8x



98-122

Lock Washer
5/16"
ZINC

8x



94-132

Plusnut
5/16"

6x



98-157

Spacer
0.375" ID, x 1.0" OD x 0.25" L
NYLON

6x



#90-212 Hex Bolt 5/16" x 1-1/4"



#98-122 Lock Washer



#98-116 Flat Washer



#94-132 Plusnut

2x



#90-220 Hex Bolt 5/16" x 1-3/4"



#98-122 Lock Washer



#98-116 Flat Washer



#98-157 Spacers
(QTY = GAP BETWEEN FLOOR AND END PANEL)



#94-132 5/16" Plusnut

PHASE 1 – ASSEMBLY

1.2 FOLD-AWAY ASSEMBLY

1.2.1 Screw the left and right end panels to the shelf tray.

×3

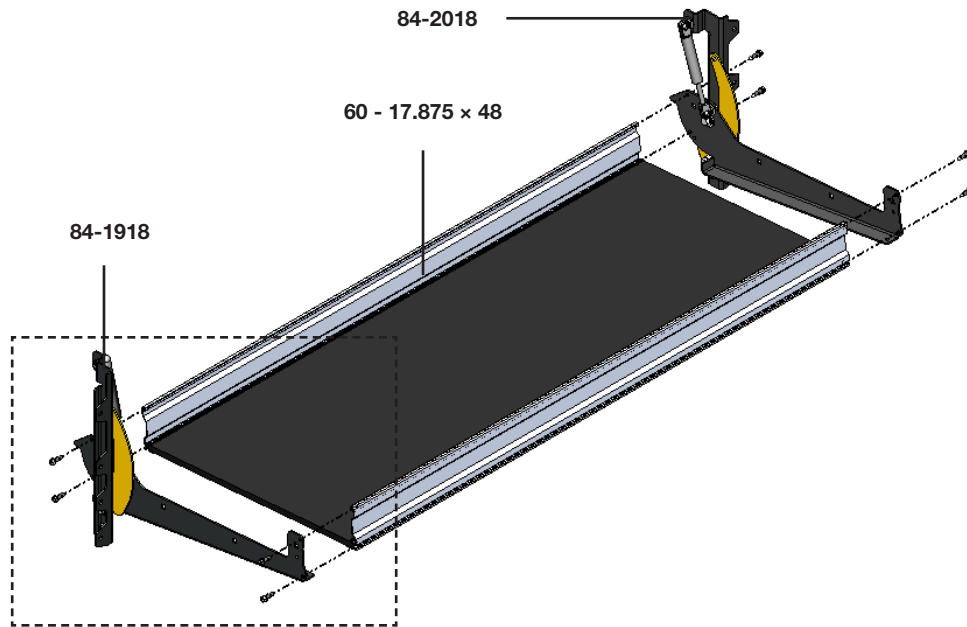

TOOLS

- Cordless Impact
- 3/8" Driver Bit

HARDWARE USED

24x

	#92-102 Screw #14 x 1"
---	------------------------

1.2.2 Rivet the end caps on the front edge of the shelf tray.

x3

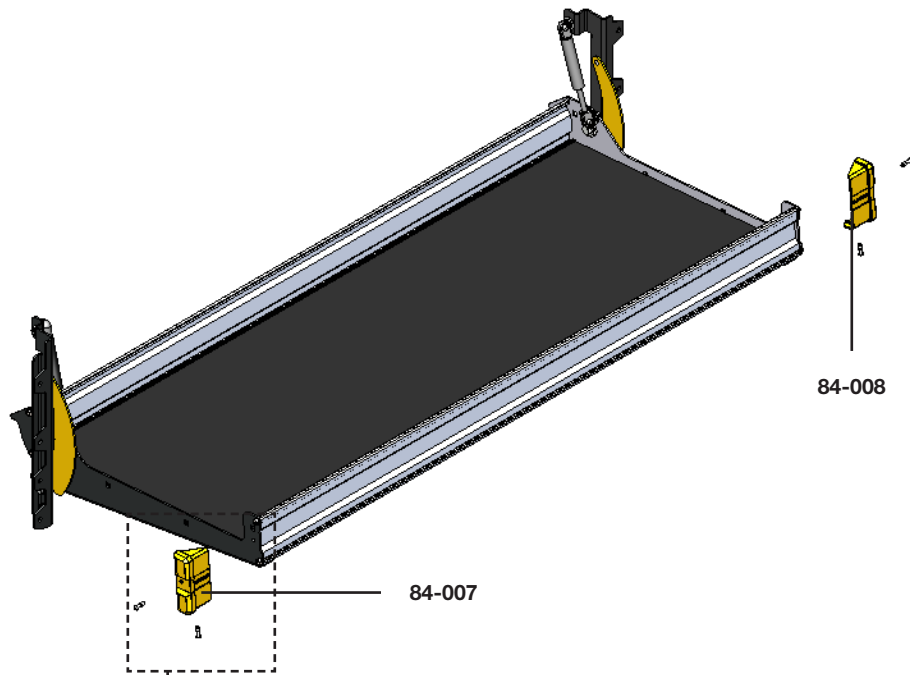

A close-up view of the end cap installation. A yellow end cap is being attached to the front edge of the shelf tray. A rivet is shown being inserted into the cap. The cap has the word "RANGER" printed on it. A rivet gun is shown being used to secure the cap.

TOOLS
□ Rivet Gun

HARDWARE USED
12x

	#96-200 Closed Rivet
---	----------------------

1.2.3 Attach the foot to the post.

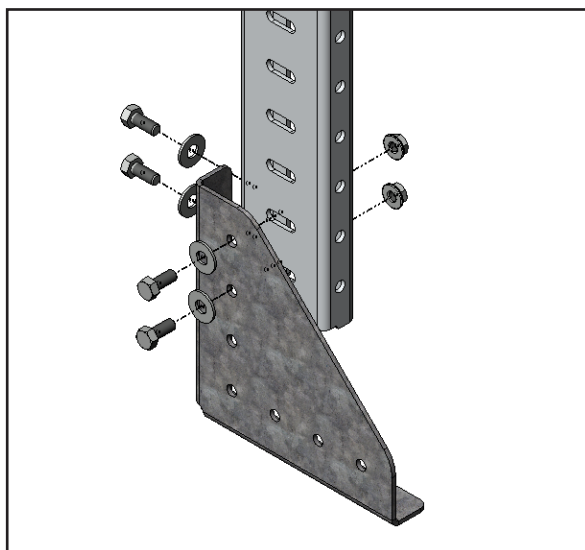
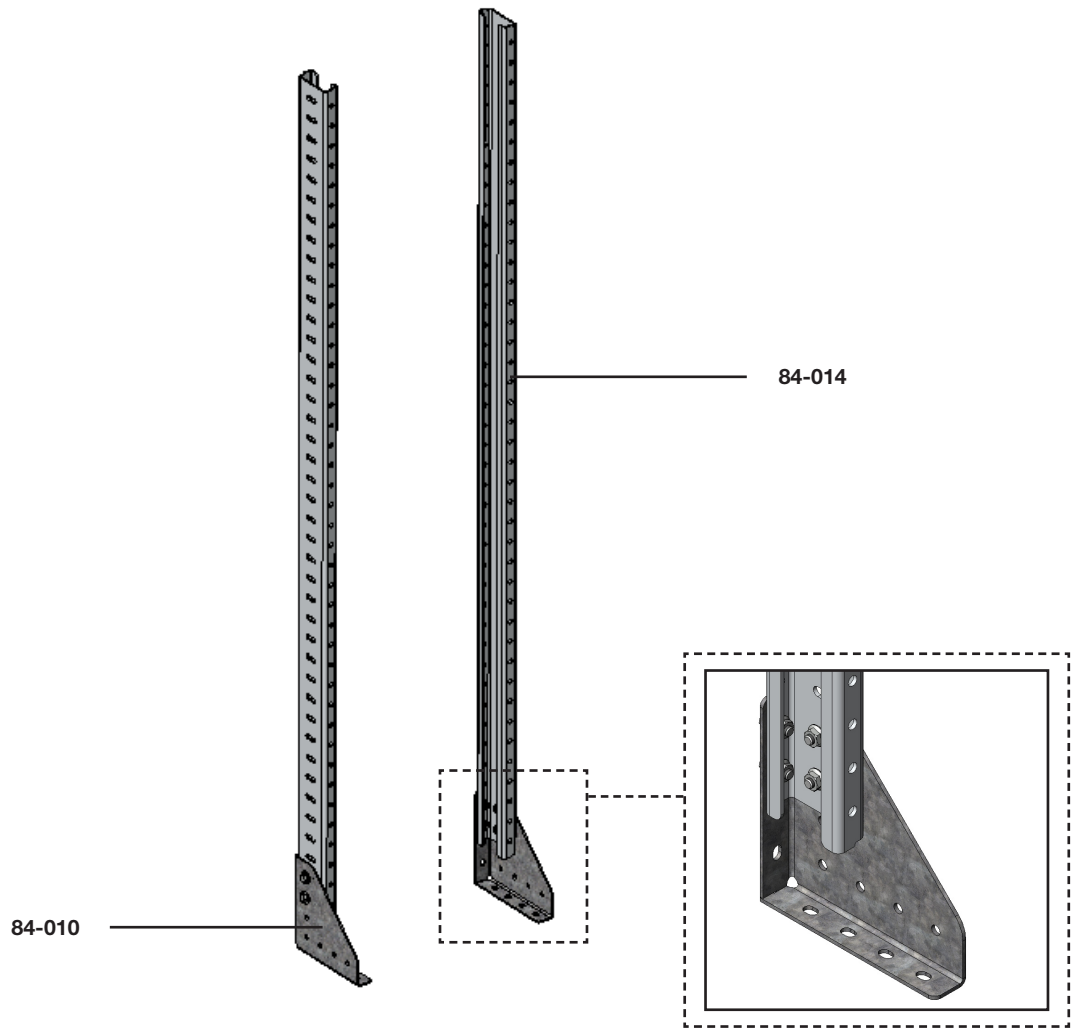



TOOLS

- Cordless Impact
- 1/2" Socket

HARDWARE USED

8x

-  #90-204 Hex Bolt 5/16" x 3/4"
-  #98-116 Flat Washer
-  #94-116 Serrated Nut

1.2.4 Attach 3 threaded plates to each post.

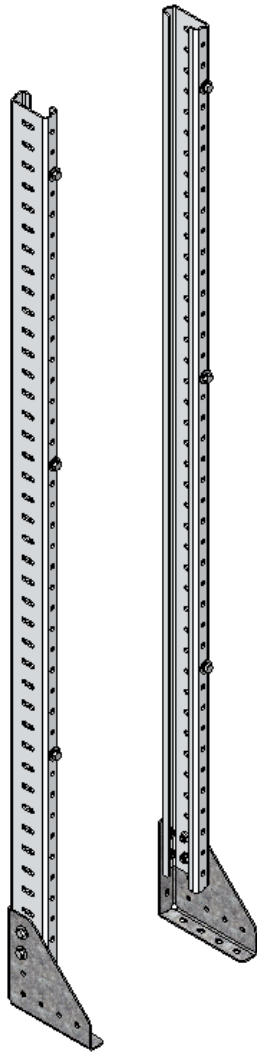



TOOLS

- ☐ Cordless Impact
- ☐ 1/2" Socket

HARDWARE USED

6x

	#90-204 Hex Bolt 5/16" x 3/4"
	#98-122 Lock Washer
	#98-116 Flat Washer

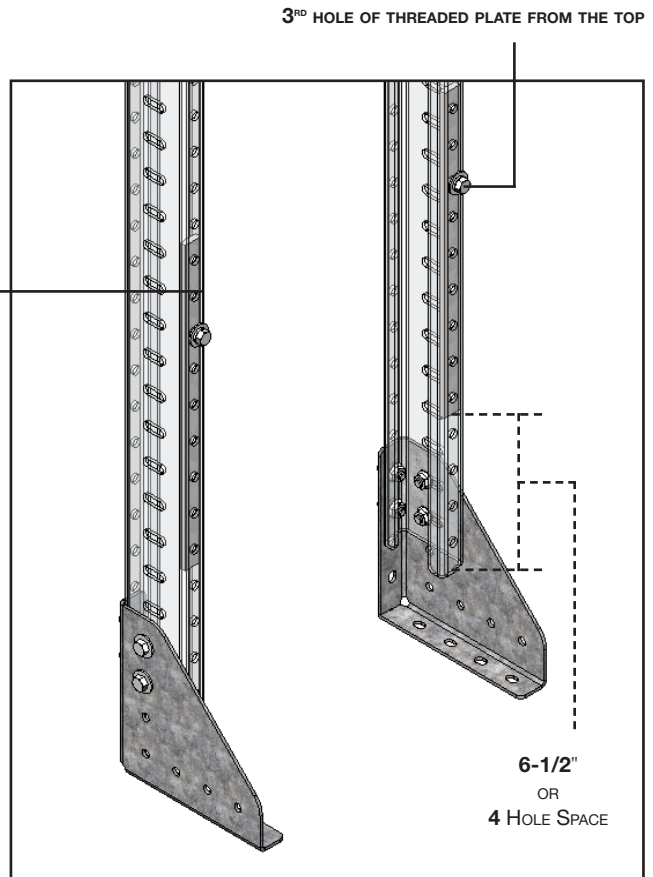
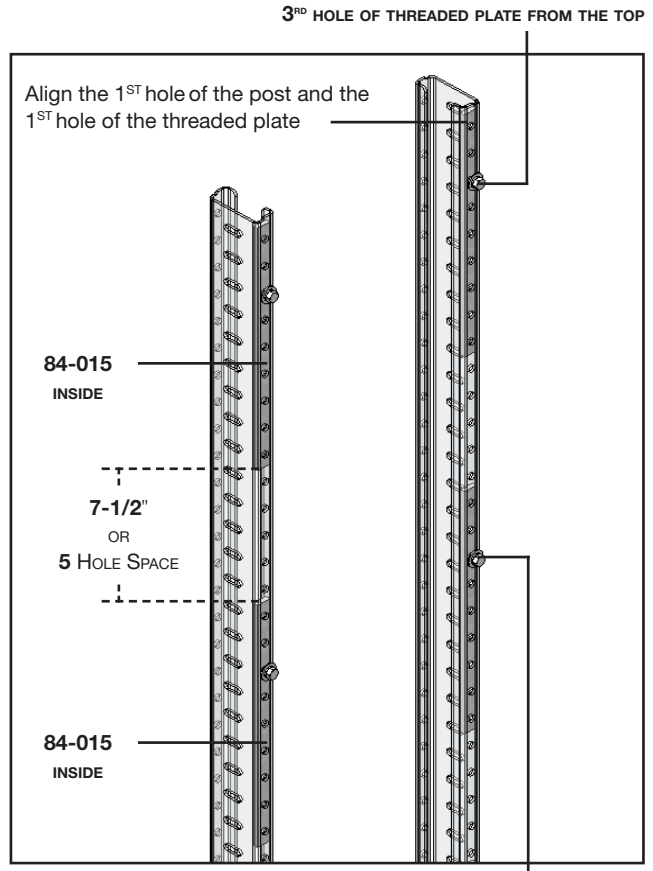

1.2.5 Attach the shelf trays to the posts.

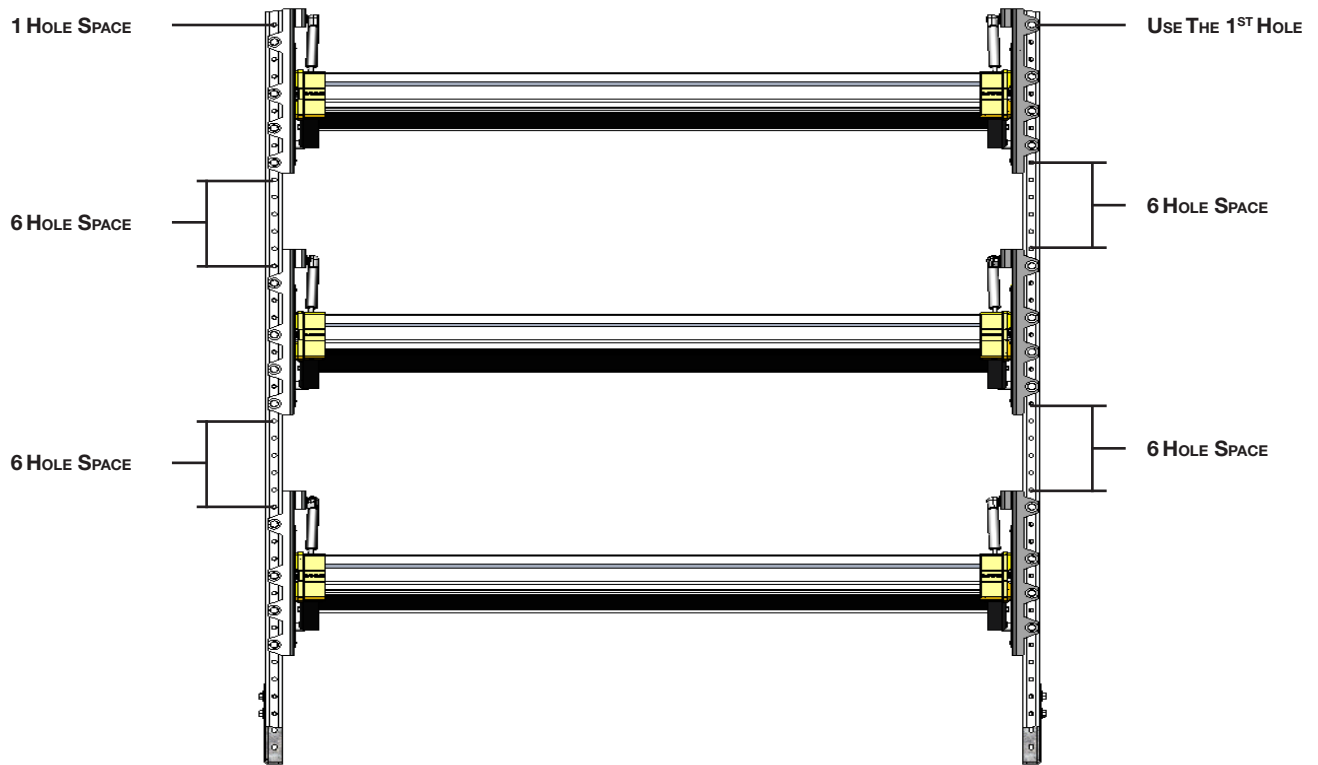



TOOLS

- Cordless Impact
- 1/2" Socket

HARDWARE USED

24x

	#90-204 Hex Bolt 5/16" x 3/4"
	#98-122 Lock Washer
	#98-116 Flat Washer

PHASE 2 – INSTALLATION

2.1 ATTACH WALL BRACKETS TO THE POSTS

- 2.1.1 • Lift the assembled fold-away to the vehicle, then put it in place.
 • Attach the top and middle bracket to the posts.

NOTE: Make sure that the posts stand vertical.

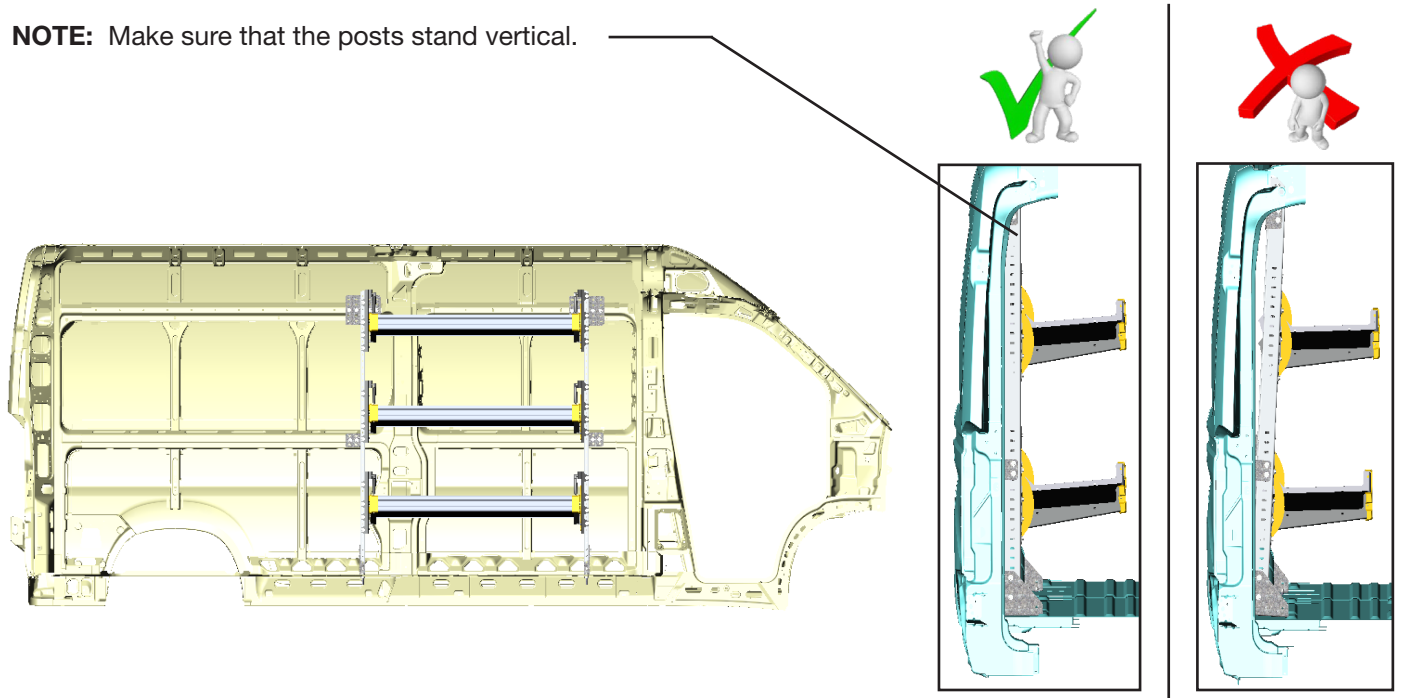

HORIZONTAL RAIL

84-011

TOOLS

- Cordless Impact
- 1/2" Socket

HARDWARE USED

4x FOR TOP BRACKET

#90-224 Hex Bolt 5/16" x 2"
 #98-116 Flat Washer
 #98-170 Spacer
 #94-116 Serrated Nut

84-012

HARDWARE USED

4x FOR MIDDLE BRACKET

#90-204 Hex Bolt 5/16" x 3/4"
 #98-116 Flat Washer
 #94-116 Serrated Nut

PHASE 2 – INSTALLATION

2.2 MARK HOLE FOR PLUSNUT

2.2.1 After attaching the brackets mark the holes on the wall brackets and feet to the vehicle.

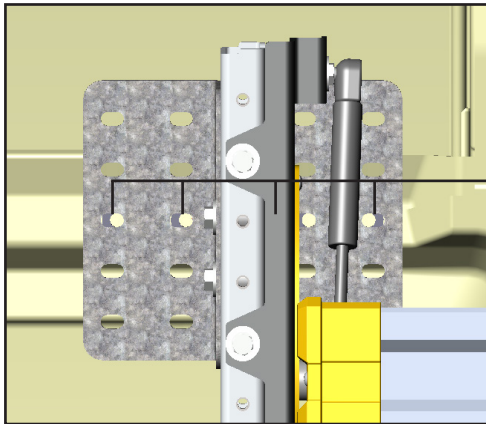
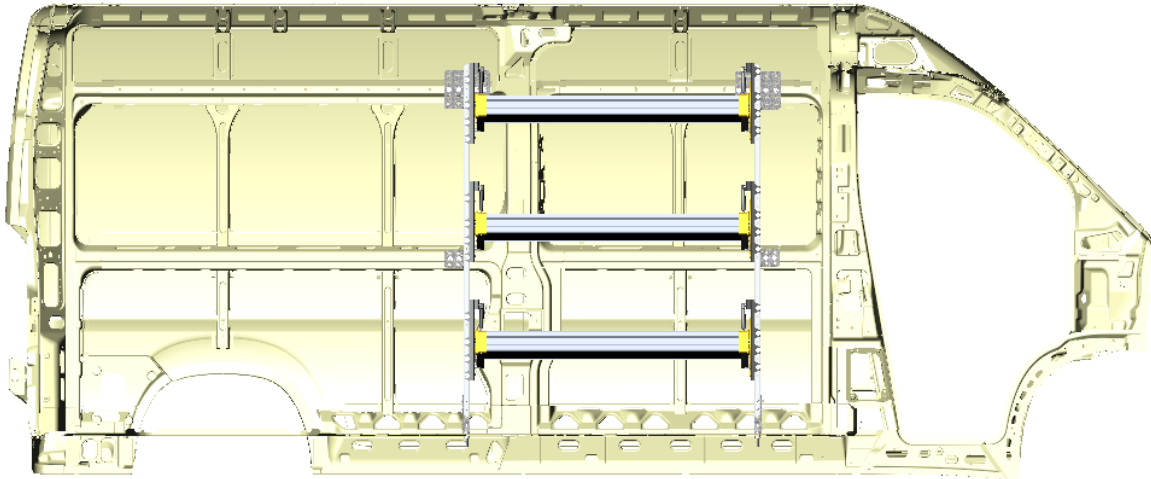

Mark 2 holes on top and middle wall brackets on the vehicle horizontal rim.

MARK

TOOLS

- Marker

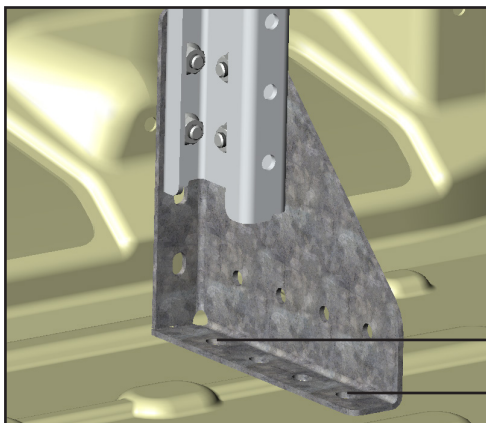

Mark the 2 holes of the feet on the vehicle floor.

MARK

PHASE 2 – INSTALLATION

2.3 ATTACH PLUSNUTS

- 2.3.1**
- Lift the assembled fold-away on the side.
 - Drill all the mark using 1/2" drill bit w/ drill collar, then attach plusnuts to the holes.

NOTE: Use 1/2" drill bit with drill collar to stop drill at 1/2" depth.

WARNING: Before drilling, ensure that you will not hit any critical parts of the vehicle like the **Gas tank**, **Wiring Harness** and **Hose**.

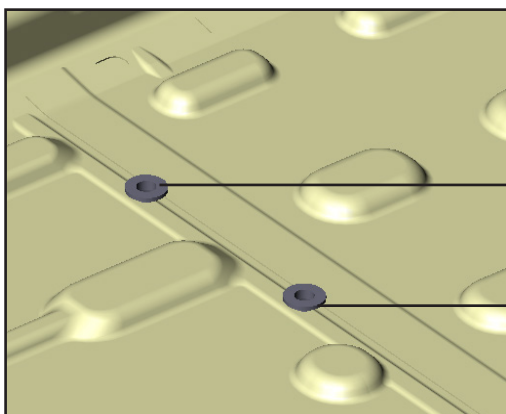
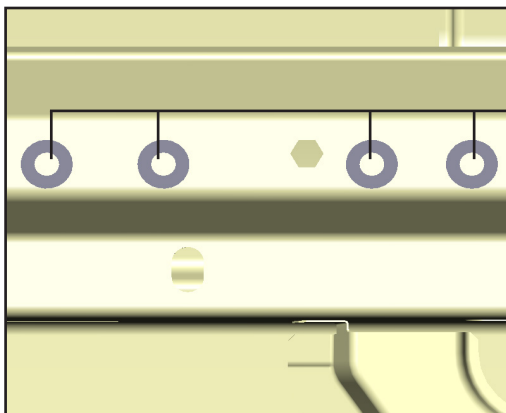
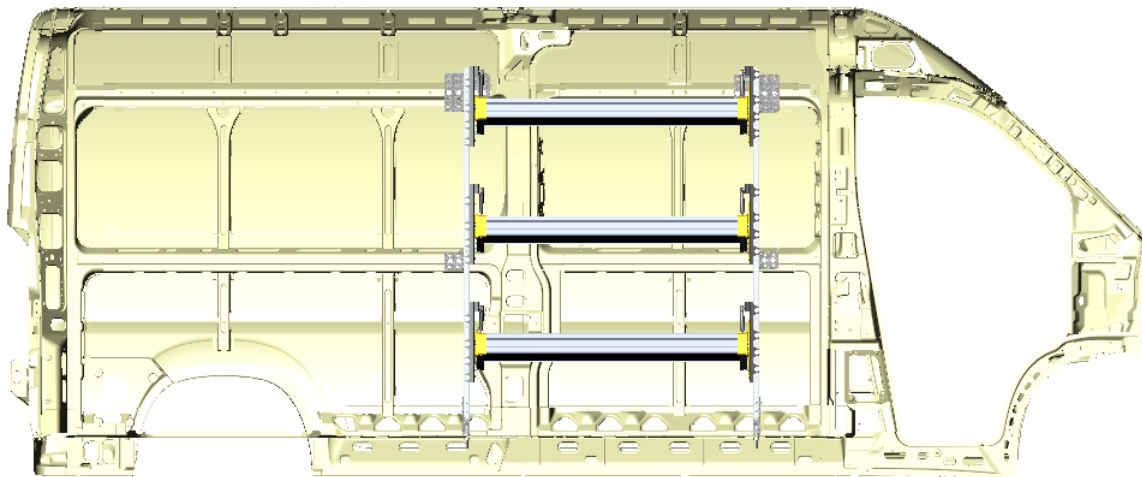

PLUS NUT

Drill all the marks then, attach plusnuts to the holes.

TOOLS

- Cordless Drill
- 1/2" Drill Bit w/ Drill Collar (Set at 1/2")
- Plusnut Tool (5/16")

HARDWARE USED

14x



#94-132 Plusnut



DRILL COLLAR
(SET AT 1/2")

2.3.2 How to attach plusnut.

• USING PLUSNUT GUN

STEP: Put the plusnut on the plusnut gun, then attach the plusnut in the hole by turning the gun forward until the plusnut locks, then remove the gun by turning in reverse.

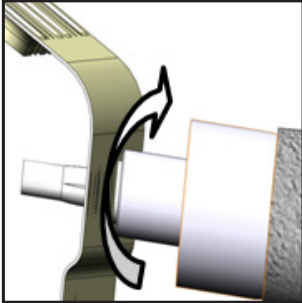

FORWARD

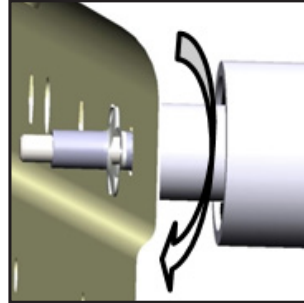

REVERSE

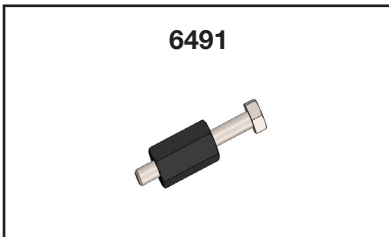

• USING THE 6491 PLUSNUT TOOL

NOTE: The hardware used for the 6490 plusnut tool is not included in the fastener bag.
The 6490 plusnut tool can be ordered separately upon demand at no charge.



6491

HARDWARE USED

-  Flat washer 5/16"
-  Flat washer 5/16" BS x 7/8" OD

TOOLS

- Cordless Impact
- 1/2" Socket
- 9/16" Wrench

STEP 1:

Assemble the 6491 plusnut tool with the hardware needed, plus nut and the 9/16" wrench as shown.



STEP 2:

Attach the plusnut in the hole by turning the bolt forward using an impact with a 1/2" socket until the plusnut locks, then remove the bolt by turning the impact in reverse.

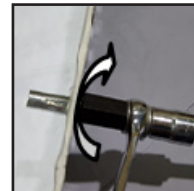

FORWARD

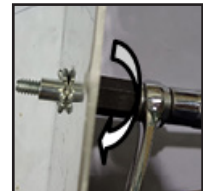

REVERSE

PHASE 2 – INSTALLATION

2.4 FOLD-AWAY INSTALLATION

2.4.1 Put the assembled fold-away back in place aligning the holes to the plusnuts, then install the wall brackets and feet to the plusnuts.

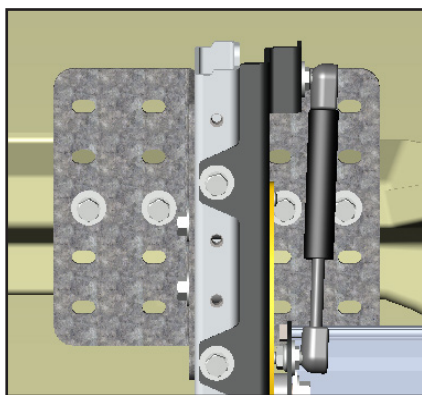
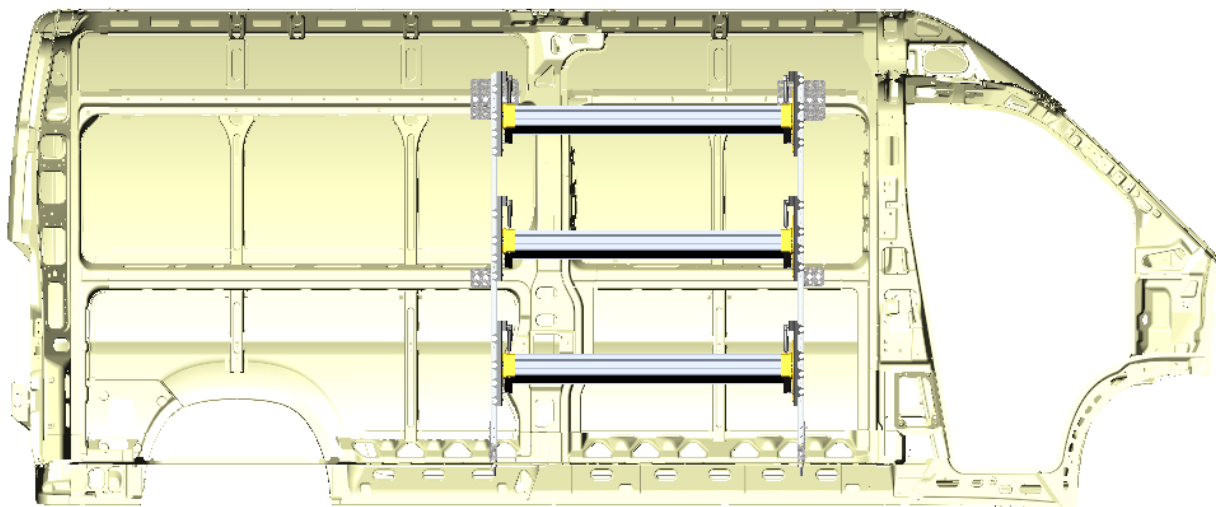





TOOLS

- Cordless Impact
- 1/2" Socket

HARDWARE USED



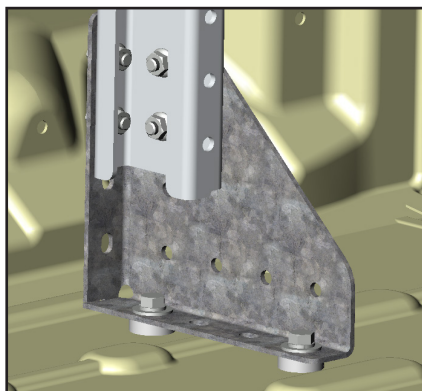

12x FOR WALL BRACKET

-  #90-212 Hex Bolt 5/16" x 1-1/4"
-  #98-122 Lock Washer
-  #98-116 Flat Washer
-  #94-132 Plus nut



HARDWARE USED

4x FOR FEET

-  #90-220 Hex Bolt 5/16" x 1-3/4"
-  #98-122 Lock Washer
-  #98-116 Flat Washer
-  #98-157 Spacers
(QTY = GAP BETWEEN FLOOR AND FEET)
-  #94-132 5/16" Plusnut

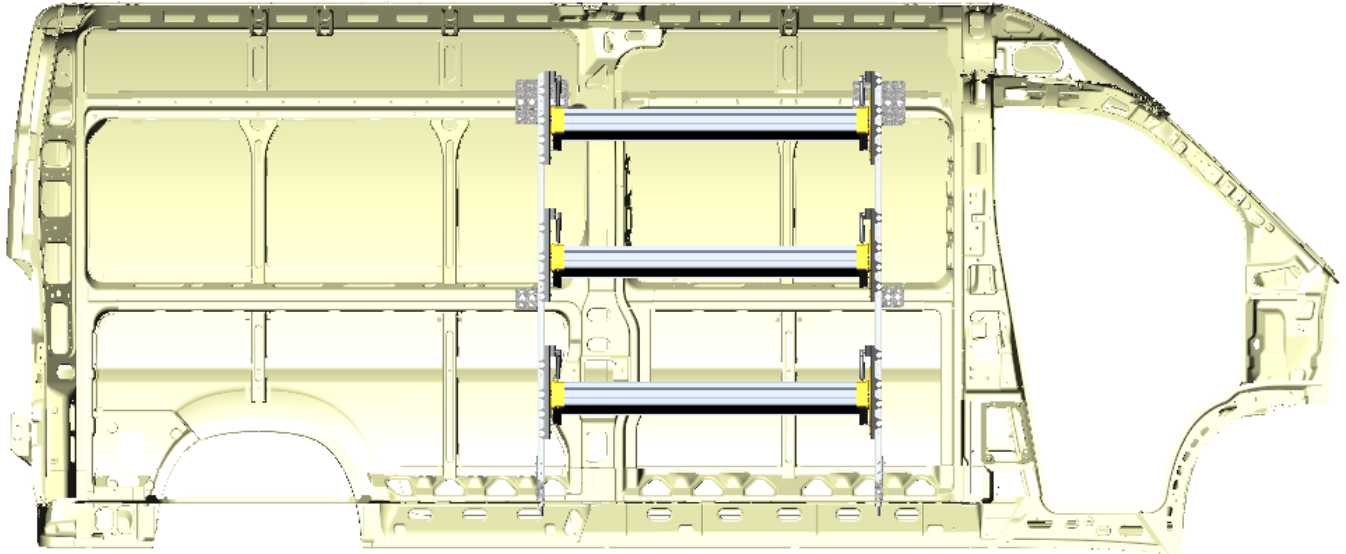

**“You have successfully installed your
Fold-Away**

Thank you for doing business with us.”

For any feedback or suggestions you may have, please contact: cs@rangerdesign.com

